

FLEXIBLE COUPLING GKF

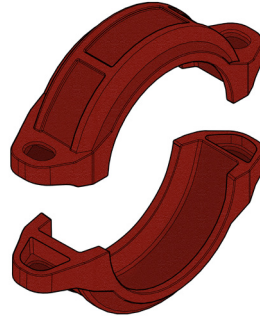
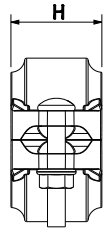
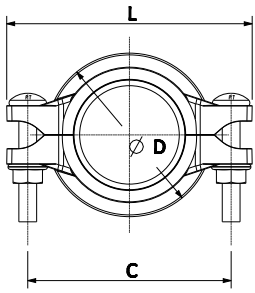

Flexible couplings are designed to allow axial displacement, rotation and some angular movement. The coupling can accommodate angular misalignments up to a few degrees. It can also accommodate parallel misalignment and/or thermal deformation when using two couplings with an intermediate pipe.

Reference		Nominal size		Pipe Ø O.D.	Flexible coupling dimensions				Bolt size	Socket wrench	Torque	Weight	Marking
Red	Galva	NPS inch	DN mm	mm	Ø D mm	L mm	H mm	C mm	d1xL mm	mm	Nm	kg	
GKFR	GKFG	1	25	33,7	55,0	97	45	73	M10x40	15	44-54	0,44	GKF
GKFR	GKFG	1¼	32	42,4	63,5	110	45	84	M10x50	15	44-54	0,50	GKF
GKFR	GKFG	1½	40	48,3	69,0	116	45	90	M10x50	15	44-54	0,54	GKF
GKFR	GKFG	2	50	57,0	83,6	124	46	102	M10x60	15	44-54	0,68*	GKF
GKFR	GKFG	2	50	60,3	83,6	127	46	102	M10x60	15	44-54	0,68	GKF
GKFR	GKFG	2½	65	73,0	98,0	137	46	115	M10x60	15	44-54	0,82	GKF
GKFR	GKFG	2½	65	76,1	98,0	139	46	115	M10x60	15	44-54	0,79	GKF
GKFR	GKFG	3	80	88,9	114,0	156	46	132	M10x60	15	44-54	0,96	GKF
GKFR	GKFG	4	100	108,0	138,0	186	50	160	M12x70	18	90-100	1,44	GKF
GKFR	GKFG	4	100	114,3	142,0	189	50	162	M12x70	18	90-100	1,39	GKF
GKFR	GKFG	5	125	133,0	164,0	213	50	185	M12x70	18	90-100	1,90*	GKF
GKFR	GKFG	5	125	139,7	170,0	222	50	192	M12x70	18	90-100	1,92	GKF
GKFR	GKFG	5	125	141,3	170,0	218	50	190	M12x70	18	90-100	1,85	GKF
GKFR	GKFG	6	150	159,0	192,0	238	50	209	M12x75	18	90-100	2,05	GKF
GKFR	GKFG	6	150	165,1	196,0	244	50	215	M12x75	18	90-100	2,11	GKF
GKFR	GKFG	6	150	168,3	198,0	251	50	222	M12x75	18	90-100	2,12	GKF
GKFR	GKFG	8	200	216,3	254,0	340	60	294	M20x90	30	270-300	4,79*	GKF
GKFR	GKFG	8	200	219,1	256,0	316	60	282	M16x85	24	200-230	3,82	GKF
GKFR	GKFG	10	250	267,4	313,0	400	64	352	M20x90	30	270-300	6,74*	GKF
GKFR	GKFG	10	250	273,0	319,0	393	64	352	M20x110	30	270-300	6,52	GKF
GKFR	GKFG	12	300	318,5	368,0	464	65	416	M22x110	34	380-420	9,03*	GKF
GKFR	GKFG	12	300	323,9	374,0	453	65	410	M20x130	30	270-300	8,55	GKF
GKFR	GKFG	14	350	355,6	408,0	510	75	454	M22x110	34	270-300	11,70*	GKF
GKFR	GKFG	15	375	377,0	428,0	520	75	468	M22x140	34	270-300	12,80*	GKF
GKFR	GKFG	16	400 ¹⁾	406,4	459,0	555	75	503	M22x140	34	270-300	15,80*	GKF
GKFR	GKFG	18	450 ¹⁾	457,0	515,0	606	78	554	M22x140	34	380-420	19,00*	GKF
GKFR	GKFG	20	500 ¹⁾	508,0	613,0	674	78	678	M22x140	34	270-300	26,00*	GKF
GKFR	GKFG	22	550 ¹⁾	558,8	621,0	782	78	678	M22x140	34	270-300	29,05*	GKF
GKFR	GKFG	24	600 ¹⁾	609,6	674,0	778	78	727	M24x150	36	320-340	32,50 *	GKF

Working pressure

300 PSI/2068 kPa

General notes:

- ¹⁾ Technical drawing on page 2 / * No FM- and UL-approval.
- Pressure ratings listed are CWP (cold working pressure) or MWP (maximum working pressure) at a maximum service temperature of 50°C. This rating may occasionally differ from maximum working pressure listed and/or approved by UL and/or FM, as testing conditions and test pipes can differ. For more information, please contact info@pipinglogistics.eu.
- The maximum working pressure listed is the total of internal and external pressures based on standard weight (ANSI) steel pipe and standard roll or cut groove in accordance with Profit specifications. For more information, please contact info@pipinglogistics.eu.
- For one time field test only, the maximum joint working pressure may be increased 150% the figure shown.
- Warning: Piping systems must always be depressurized and drained before attempting disassembly and/or removal of any components.
- Profit reserves the right to change specifications, designs and/or standard equipment without notice and without incurring in any obligations.
- Profit red coated products are intended for piping with indoor application (EN 12944-2 corrosivity category C1 & C2). For outdoor installations near the sea (corrosivity category C3) we advise the use of our hot dip galvanized couplings and fittings. For application in corrosivity category C4 (higher salinity climate) or higher, please contact info@pipinglogistics.eu.
- We advise to always store our products in closed and dry environments.
- Independent technical datasheet for bolts, nuts and rubber gaskets.

Technical drawing for

- GKFR16 and GKFG16 (DN 400)
- GKFR18 and GKFG18 (DN 450)
- GKFR20 and GKFG20 (DN 500)
- GKFR22 and GKFG22 (DN 550)
- GKFR24 and GKFG24 (DN 600)

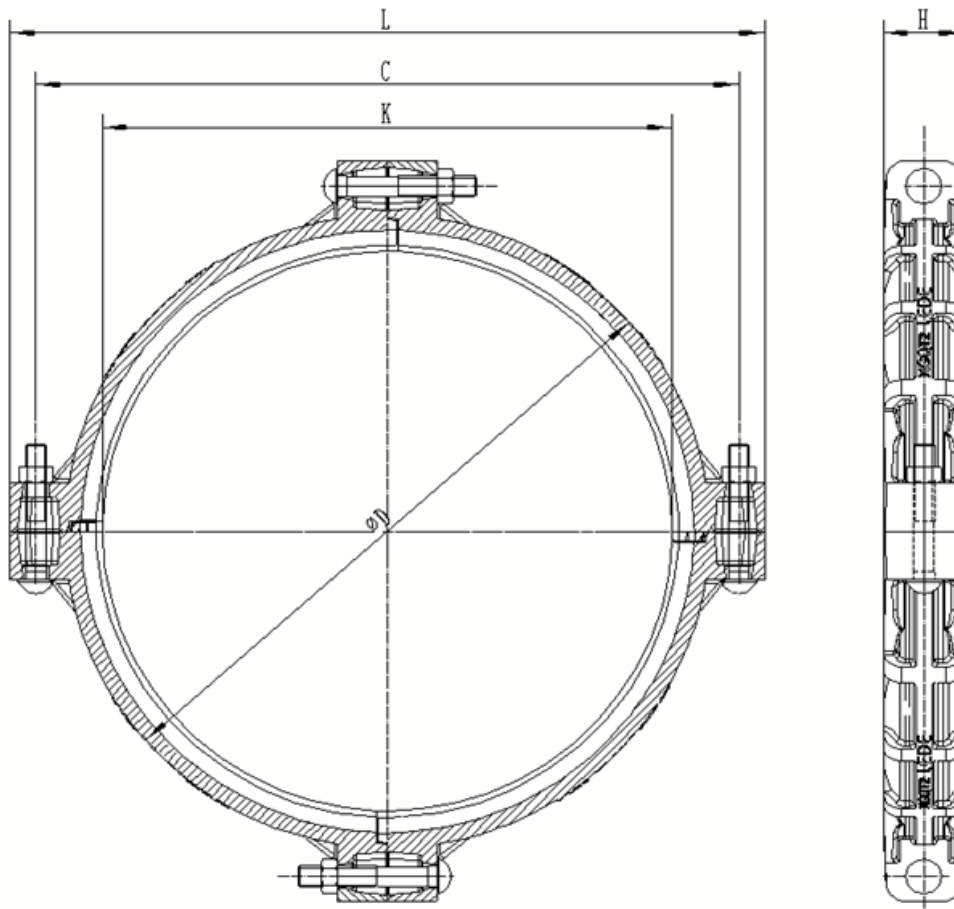

Material specifications

Housing: ductile iron conform to ASTM A536 GR 65-45-12

Coating:

- Hot dip galvanized
- Red paint coating RAL 3000, EPD Epoxy coating

Bolts and nuts: medium carbon steel, zinc electroplated, quenched and tempered

Rubber gasket: EPDM gaskets are in accordance with the international certifications and have undergone the aging test at 110C/230°F for a period of 45 days/1080 hours and the frozen test at -40°C/-40°F for a period of 4 days/96 hours.

Nominal size		Pipe Ø O.D.	W	A mm			X mm
NPS inch	DN mm	mm	mm	basic	max.	min.	max.
1	25	33,7	35,0	15,9	16,6	15,1	1,6
1¼	32	42,4	35,0	15,9	16,6	15,1	1,6
1½	40	48,3	35,0	15,9	16,6	15,1	1,6
2	50	57,0	35,0	15,9	16,6	15,1	1,6
2	50	60,3	35,0	15,9	16,6	15,1	1,6
2½	65	73,0	35,0	15,9	16,6	15,1	1,6
2½	65	76,1	35,0	15,9	16,6	15,1	1,6
3	80	88,9	35,0	15,9	16,6	15,1	1,6
4	100	108,0	37,0	15,9	16,6	15,1	3,2
4	100	114,3	37,0	15,9	16,6	15,1	3,2
5	125	133,0	37,0	15,9	16,6	15,1	3,2
5	125	139,7	37,0	15,9	16,6	15,1	3,2
5	125	141,3	37,0	15,9	16,6	15,1	3,2
6	150	159,0	37,5	15,9	16,6	15,1	3,2
6	150	165,1	37,5	15,9	16,6	15,1	3,2
6	150	168,3	37,5	15,9	16,6	15,1	3,2
8	200	216,3	44,5	19,1	19,8	18,3	3,2
8	200	219,1	44,5	19,1	19,8	18,3	3,2
10	250	267,4	47,0	19,1	19,8	18,3	3,2
10	250	273,0	47,0	19,1	19,8	18,3	3,2
12	300	318,5	48,0	19,1	19,8	18,3	3,2
12	300	323,9	48,0	19,1	19,8	18,3	3,2

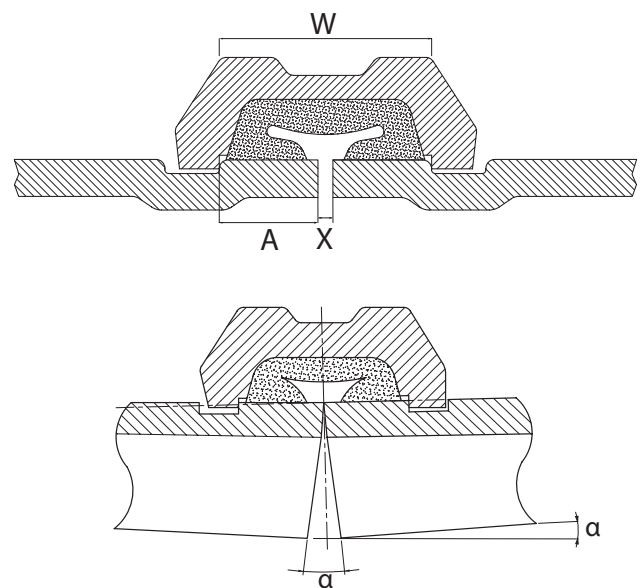

General notes:

- The maximum axial and angular movement values shown in the table are valid for rolled groove, they may be doubled for cut groove. For design and installation purposes, we recommend to reduce these values by 50% (1"-3") and by 25% (4"-10").
- Combined maximum angular and maximum axial movement are not allowed. Contact us for more information.
- Our flexible couplings meet the minimum required allowable angular movements according to NFPA 13-3.5.8.
- Profit flexible couplings provide cost-effective solutions for expansion problems, vibrations, pipe stress, seismic loads etc.
- Pressure ratings listed are CWP (cold working pressure) or MWP (maximum working pressure) at a maximum service temperature of 50°C. This rating may occasionally differ from maximum working pressure listed and/or approved by UL and/or FM, as testing conditions and test pipes can differ. For more information, please contact info@pipinglogistics.eu.
- The maximum working pressure listed is the total of internal and external pressures based on standard weight (ANSI) steel pipe and standard roll or cut groove in accordance with Profit specifications. For more information, please contact info@pipinglogistics.eu.
- For one time field test only, the maximum joint working pressure may be increased 150% the figure shown.
- Warning: Piping systems must always be depressurized and drained before attempting disassembly and/or removal of any components.
- Profit reserves the right to change specifications, designs and/or standard equipment without notice and without incurring in any obligations.
- Profit red coated products are intended for piping with indoor application (EN 12944-2 corrosivity category C1 & C2). For outdoor installations near the sea (corrosivity category C3) we advise to use our hot dip galvanized couplings and fittings. For application in corrosivity category C4 (higher salinity climate) or higher, please contact info@pipinglogistics.eu.
- We strongly advise to always store our products in closed and dry warehouses.
- Independent technical datasheet for bolts, nuts and rubber gaskets.
- Working pressure for 20", 22" and 24": 232 PSI (1600 kPa). Maximum test pressure = 470 PSI/3200 kPa.

FLEXIBLE COUPLING GKF

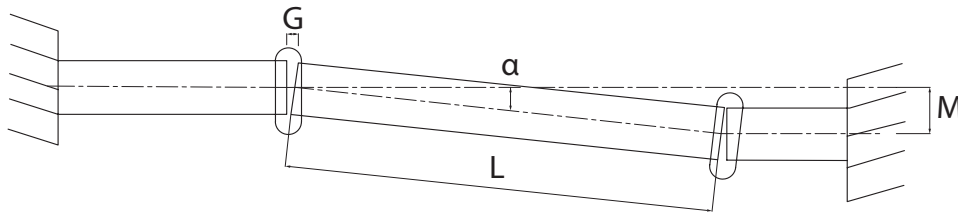

Nominal size		Pipe Ø O.D.	Deflection	
NPS inch	DN mm	mm	α (°)	M* mm
1	25	33,7	2,3	40
1¼	32	42,4	2	34
1½	40	48,3	2	34
2	50	57,0	1,5	26
2	50	60,3	1,5	26
2½	65	73,0	1	17
2½	65	76,1	1	17
3	80	88,9	1	17
4	100	108,0	1	17
4	100	114,3	1	17
5	125	133,0	1	17
5	125	139,7	1	17
5	125	141,3	1	17
5	150	159,0	1	17
6	150	165,1	1	17
6	150	168,3	1	17
6	200	216,3	1	17
8	200	219,1	1	17
10	250	267,4	0,5	8
10	250	273,0	0,5	8
12	300	318,5	0,5	8
12	300	323,9	0,5	8

* when L = 1m

Above 12": data on request.

General notes:

- The maximum axial and angular movement values shown in the table are valid for rolled groove, they may be doubled for cut groove. For design and installation purposes, we recommend to reduce these values by 50% (1"-3") and by 25% (4"-10").
- Combined maximum angular and maximum axial movement are not allowed. Contact us for more information.
- Our flexible couplings meet the minimum required allowable angular movements according to NFPA 13-3.5.8.
- Profit flexible couplings provide cost-effective solutions for expansion problems, vibrations, pipe stress, seismic loads etc.
- Pressure ratings listed are CWP (cold working pressure) or MWP (maximum working pressure) at a maximum service temperature of 50°C. This rating may occasionally differ from maximum working pressure listed and/or approved by UL and/or FM, as testing conditions and test pipes can differ. For more information, please contact info@pipinglogistics.eu.
- The maximum working pressure listed is the total of internal and external pressures based on standard weight (ANSI) steel pipe and standard roll or cut groove in accordance with Profit specifications. For more information, please contact info@pipinglogistics.eu.
- For one time field test only, the maximum joint working pressure may be increased 150% the figure shown.
- Warning: Piping systems must always be depressurized and drained before attempting disassembly and/or removal of any components.
- Profit reserves the right to change specifications, designs and/or standard equipment without notice and without incurring in any obligations.
- Profit red coated products are intended for piping with indoor application (EN 12944-2 corrosivity category C1 & C2). For outdoor installations near the sea (corrosivity category C3) we advise to use our hot dip galvanized couplings and fittings. For application in corrosivity category C4 (higher salinity climate) or higher, please contact info@pipinglogistics.eu.
- We strongly advise to always store our products in closed and dry warehouses.
- Independent technical datasheet for bolts, nuts and rubber gaskets.

MINIMUM PIPE WALL THICKNESS

Allowable minimum pipe wall thickness combinations with PROFIT - couplings GKS and GKF and rolled grooves.

Nominal pipe size		Minimum thickness T* (Not FM approved) MPW = 12 barg	Minimum thickness T** MWP = 20,7 Barg	Minimum thickness T*** Only combined with FM-approved pipes	
				Thickness (mm)	MWP (Barg)
NPS (DN)		mm	mm		
1	25	1,65	2,77	1,6	12
1¼	32	1,65	2,77	1,6	12
1½	40	1,65	2,77	1,6	12
2	50	1,65	2,77	1,6	12
2½	65	2,11	3,05	1,8	12
3	80	2,11	3,05	2,36	20,7
4	100	2,11	3,05	2,49	20,7
5	125	2,77	3,40	-	-
6	150	2,77	3,40	2,98	12
8	200	2,77	4,00	-	-
10	250	3,40	5,00	-	-
12	300	3,96	6,70	-	-
14	350	3,96	-	-	-
15	375	3,96	-	-	-
16	400	4,19	-	-	-
17	425	4,19	-	-	-
18	450	4,19	-	-	-
20	500	4,78	-	-	-
22	550	5,54	-	-	-
24	600	5,54	-	-	-

T* According to standard AWWA C606-2006 (Pipes Sch5-ASME B36.10)

T** For FM-application when couplings are combined with pipes with wall thickness bigger than the minimum thickness according to FM Property Loss Prevention datasheet 2-0.

T*** For FM-application only when combination of coupling and pipe are FM-listed.

MWP= maximum working pressure

For installations within Europe (EC) please note that the minimum pipe thickness in fire sprinkler piping should be according to standard EN 12845.