

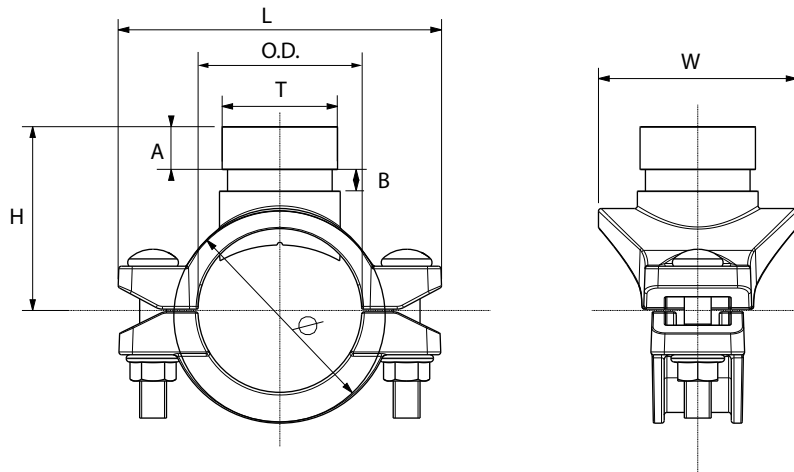

Mechanical tees with grooved outlet can be used for any tee connection where a grooved outlet is needed. They may be converted into a cross when necessary.



Material specifications

Housing: ductile iron conform to ASTM A536 GR65-45-12

Coating

- Hot dip galvanized
- Red paint coating RAL 3000, EPD Epoxy coating

Rubber gasket: EPDM gaskets dispose of the international certifications and have undergone the aging test at 110C/230°F during a period of 45 days/1080 hours and the frozen test at -40°C/-40°F during a period of 4 days/96 hours.

Bolts and nuts: see technical datasheet bolts and nuts

Working pressure

300 PSI/2068 kPa

General notes:

- Pressure ratings listed are CWP (cold working pressure) or MWP (maximum working pressure) at a maximum service temperature of 50°C. This rating may occasionally differ from maximum working pressure listed and/or approved by UL and/or FM, as testing conditions and test pipes can differ. For more information, please contact info@pipinglogistics.eu.
- Maximum working pressure listed is the total of internal and external pressures based on standard weight (ANSI) steel pipe and standard roll or cut groove in accordance with Profit specifications. For more information, please contact info@pipinglogistics.eu.
- For one time field test only, the maximum joint working pressure may be increased by 150% the figure shown.
- Warning: Piping systems must always be depressurized and drained before attempting disassembly and/or removal of any components.
- Profit reserves the right to change specifications, designs and/or standard equipment without notice and without incurring in any obligations.
- Profit red coated products are intended for piping with indoor application (EN 12944-2 corrosivity category C1 & C2). For outdoor installations near the sea (corrosivity category C3) we advise the use of our hot dip galvanized couplings and fittings. For application in corrosivity category C4 (higher salinity climate) or higher, please contact info@pipinglogistics.eu.
- We advise to always store our products in closed and dry environments.

MECHANICAL TEE GROOVED OUTLET GMG

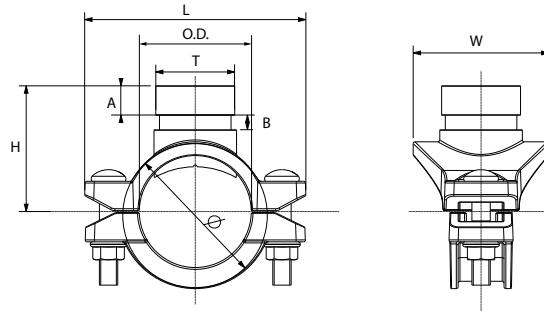

Reference		Nominal size Run - reducing outlet		Pipe Ø O.D. - T	Grooved mechanical tee dimensions						Working pressure	Hole cut*	Bolt size	Socket wrench	Bolt torque	Weight	Marking
Red	Galva	NPS inch	DN mm	mm	Ø mm	L mm	H mm	W mm	A mm	B mm	PSI	mm	d1xL	mm	Nm	kg	
GMGR	GMGG	2 - 1	50-25	60,3 - 33,7	85	120	69	70	15,9	7,9	300	46+1	M10x50	15	75-80	0,90 ³⁾	GMG
GMGR	GMGG	2 - 1¼	50-32	60,3 - 42,4	85	120	69	70	15,9	7,9	300	46+1	M10x50	15	44-54	0,91	GMG
GMGR	GMGG	2 - 1½	50-40	60,3 - 48,3	85	120	69	70	15,9	7,9	300	46+1	M10x50	15	44-54	0,94	GMG
GMGR	GMGG	2½ - 1	65-25	76,1 - 33,7	96	139	76	70	15,9	7,9	300	46+1	M10x60	15	44-54	1,00 ¹⁾	GMG
GMGR	GMGG	2½ - 1¼	65-32	73,0 - 42,4	96	139	74	73	15,9	7,9	300	46+1	M10x60	15	44-54	1,00	GMG
GMGR	GMGG	2½ - 1½	65-40	73,0 - 48,3	96	139	74	75	15,9	7,9	300	53+1	M10x60	15	44-54	1,10	GMG
GMGR	GMGG	2½ - 1¾	65-32	76,1 - 42,4	99	139	76	74	15,9	7,9	300	46+1	M10x60	15	44-54	1,02	GMG
GMGR	GMGG	2½ - 1½	65-40	76,1 - 48,3	99	139	77	82	15,9	7,9	300	53+1	M10x60	15	44-54	1,07	GMG
GMGR	GMGG	2½ - 2	65-50	76,1 - 60,3	99	139	77	82	15,9	7,9	300	53+1	M10x60	15	44-54	1,18 ¹⁾	GMG
GMGR	GMGG	3 - 1	80-25	88,9 - 33,7	113	155	85	82	15,9	7,9	300	38+1	M10x60	15	44-54	1,14 ¹⁾	GMG
GMGR	GMGG	3 - 1¼	80-32	88,9 - 42,4	113	155	85	95,5	15,9	7,9	300	46+1	M10x60	15	44-54	1,12	GMG
GMGR	GMGG	3 - 1½	80-40	88,9 - 48,3	113	155	85	95,5	15,9	7,9	300	53+1	M10x60	15	44-54	1,14	GMG
GMGR	GMGG	3 - 2	80-50	88,9 - 60,3	113	155	85	95,5	15,9	7,9	300	64+1	M10x60	15	44-54	1,35	GMG
GMGR	GMGG	4 - 2	100-50	108 - 60,3	132	172	95,5	99	15,9	7,9	300	64+1	M12x70	18	90-100	1,55 ²⁾	GMG
GMGR	GMGG	4 - 1	100-25	114,3 - 33,7	139	181	97,5	96	15,9	7,9	300	38+1	M12x70	18	90-100	1,48 ¹⁾	GMG
GMGR	GMGG	4 - 1¼	100-32	114,3 - 42,4	139	181	97,5	110	15,9	7,9	300	46+1	M12x70	18	90-100	1,37	GMG
GMGR	GMGG	4 - 1½	100-40	114,3 - 48,3	139	181	97,5	113	15,9	7,9	300	53+1	M12x70	18	90-100	1,41	GMG
GMGR	GMGG	4 - 2	100-50	114,3 - 60,3	139	181	97,5	125	15,9	7,9	300	64+1	M12x70	18	90-100	1,53	GMG
GMGR	GMGG	4 - 2½	100-65	114,3 - 73,0	139	181	98	125	15,9	7,9	300	70+1	M12x70	18	90-100	1,85	GMG
GMGR	GMGG	4 - 2½	100-65	114,3 - 76,1	139	181	98	126	15,9	7,9	300	70+1	M12x70	18	90-100	1,86	GMG
GMGR	GMGG	4 - 3	100-80	114,3 - 88,9	139	181	95	127	15,9	7,9	232	89+1	M12x70	18	90-100	2,04 ¹⁾	GMG
GMGR	GMGG	5 - 1½	125-40	139,7 - 48,3	167	212	110	127	15,9	7,9	300	53+1	M12x75	18	90-100	2,00	GMG
GMGR	GMGG	5 - 2	125-50	139,7 - 60,3	167	212	110	127	15,9	7,9	300	64+1	M12x75	18	90-100	1,96	GMG
GMGR	GMGG	5 - 2½	125-65	139,7 - 73,0	168	219	112	154	15,9	7,9	300	70+1	M16x85	24	200-230	2,30	GMG
GMGR	GMGG	5 - 2½	125-65	139,7 - 76,1	168	219	112	154	15,9	7,9	300	70+1	M16x85	14	200-230	2,44 ²⁾	GMG
GMGR	GMGG	5 - 3	125-80	139,7 - 88,9	168	219	112	136	15,9	7,9	300	89+1	M16x85	24	200-230	3,24 ²⁾	GMG
GMGR	GMGG	5 - 1½	125-40	141,3 - 48,3	167	212	110	82	15,9	7,9	300	53+1	M12x75	18	90-100	2,00	GMG
GMGR	GMGG	5 - 2	125-50	141,3 - 60,3	167	212	110	93	15,9	7,9	300	64+1	M12x75	18	90-100	2,80	GMG
GMGR	GMGG	5 - 2½	125-65	141,3 - 73,0	168	219	112	117	15,9	7,9	300	70+1	M16x85	24	200-230	2,45 ¹⁾	GMG
GMGR	GMGG	5 - 2½	125-65	141,3 - 76,1	168	219	112	117	15,9	7,9	300	70+1	M16x85	24	200-230	2,45 ²⁾	GMG
GMGR	GMGG	5 - 3	125-80	141,3 - 88,9	168	219	112	136	15,9	7,9	300	89+1	M16x85	24	200-230	3,24 ²⁾	GMG
GMGR	GMGG	6 - 2	150-50	159,0 - 60,3	184	236	120,5	93	15,9	7,9	300	64+1	M16x85	24	200-230	2,67 ²⁾	GMG
GMGR	GMGG	6 - 2	150-50	165,1 - 60,3	191	248	125	93	15,9	7,9	300	64+1	M16x85	24	200-230	2,59	GMG
GMGR	GMGG	6 - 2½	150-65	165,1 - 73,0	191	248	125	117	15,9	7,9	300	70+1	M16x85	24	200-230	2,93 ²⁾	GMG
GMGR	GMGG	6 - 2½	150-65	165,1 - 76,1	191	248	125	117	15,9	7,9	300	70+1	M16x85	24	200-230	2,93	GMG
GMGR	GMGG	6 - 3	150-80	165,1 - 88,9	191	248	125	137	15,9	7,9	300	89+1	M16x85	24	200-230	2,76 ²⁾	GMG
GMGR	GMGG	6 - 4	150-100	165,1 - 114,3	191	248	129	162	15,9	7,9	232	114+1	M16x85	24	200-230	3,52 ²⁾	GMG
GMGR	GMGG	6 - 1¼	150-32	168,3 - 42,4	194	248	124	73	15,9	7,9	300	46+1	M16x85	24	200-230	2,51	GMG
GMGR	GMGG	6 - 1½	150-40	168,3 - 48,3	194	248	124	80	15,9	7,9	300	53+1	M16x85	24	200-230	2,53	GMG

Reference		Nominal size Run - reducing outlet		Pipe Ø O.D. - T	Grooved mechanical tee dimensions						Working pressure	Hole cut*	Bolt size	Socket wrench	Bolt torque	Weight	Marking
Red	Galva	NPS inch	DN mm	mm	Ø mm	L mm	H mm	W mm	A mm	B mm	PSI	mm	d1xL	mm	Nm	kg	
GMGR	GMGG	6 - 2	150-50	168,3 - 60,3	194	248	125	91	15,9	7,9	300	64+1	M16x85	24	200-230	2,54	GMG
GMGR	GMGG	6 - 2½	150-65	168,3 - 73,0	194	248	126	117	15,9	7,9	300	70+1	M16x85	24	200-230	2,82	GMG
GMGR	GMGG	6 - 2½	150-65	168,3 - 76,1	194	248	126	117	15,9	7,9	300	70+1	M16x85	24	200-230	2,87	GMG
GMGR	GMGG	6 - 3	150-80	168,3 - 88,9	194	248	126	136	15,9	7,9	232	89+1	M16x85	24	200-230	3,00	GMG
GMGR	GMGG	6 - 4	150-100	168,3 - 114,3	194	248	129	162	15,9	9,5	232	114+1	M16x85	24	200-230	3,47	GMG
GMGR	GMGG	8 - 2	200-50	219,1 - 60,3	248	311	152	93	15,9	7,9	300	64+1	M16x85	24	200-230	3,47 ¹⁾	GMG
GMGR	GMGG	8 - 2½	200-65	219,1 - 73,0	248	322	154	117	15,9	7,9	300	70+1	M20x90	30	270-300	4,56	GMG
GMGR	GMGG	8 - 2½	200-65	219,1 - 76,1	248	322	154	117	15,9	7,9	300	70+1	M20x90	24	200-230	3,93	GMG
GMGR	GMGG	8 - 3	200-80	219,1 - 88,9	248	322	154	136	15,9	7,9	300	89+1	M20x90	24	200-230	4,13	GMG
GMGR	GMGG	8 - 4	200-100	219,1 - 114,3	248	322	154	162	15,9	7,9	300	114+1	M20x90	30	270-300	5,30 ³⁾	GMG

LABEL EXAMPLE

Mechanical tee	
GMG (Grooved)	
4-21/2	5-21/2
6-21/2	8-21/2
Hole cut dimension	
70(+1mm)	

- * Please note that the **correct hole cut dimension** is mentioned:
- on the label which is attached to the product itself
 - on the document called 'Hole cut dimensions', which is added to each delivery from our warehouse Piping Logistics, Belgium. This document is attached to the outside of the first box in a plastic pouch with reference 'Documents enclosed'

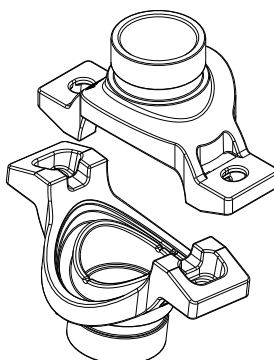

Mechanical cross** conversion				
	Main pipe diameter		Maximum outlet mechanical cross	
Inch	DN	OD	DN	OD
2,5	65	76,1	32	42,4
3	80	88,9	40	48,3
4	100	114,3	50	60,3
5	125	139,7	65	76,1
6	150	168,3	80	88,9
8	200	219,1	100	114,3

**Mechanical cross not FM and UL certified.

General notes:

- ¹⁾ No FM- and UL-approval / ²⁾ No UL-approval / ³⁾ No FM-approval
- Pressure ratings listed are CWP (cold working pressure) or MWP (maximum working pressure) at a maximum service temperature of 50°C. This rating may occasionally differ from maximum working pressure listed and/or approved by UL and/or FM, as testing conditions and test pipes can differ. For more information, please contact info@pipinglogistics.eu.
- Maximum working pressure listed is total of internal and external pressures based on standard weight (ANSI) steel pipe and standard roll or cut groove in accordance with Profit specifications. For more information, please contact info@pipinglogistics.eu.
- For one time field test only, the maximum joint working pressure may be increased by 150% the figure shown.
- Warning: Piping systems must always be depressurized and drained before attempting disassembly and/or removal of any components.
- Profit reserves the right to change specifications, designs and/or standard equipment without notice and without incurring in any obligations.
- Profit red coated products are intended for piping with indoor application (EN 12944-2 corrosivity category C1 & C2). For outdoor installations near the sea (corrosivity category C3) we advise the use of our hot dip galvanized couplings and fittings. For application in corrosivity category C4 (higher salinity climate) or higher, please contact info@pipinglogistics.eu.
- We advise to always store our products in closed and dry environments.