

GROOVED ELBOW 11,25° GB11

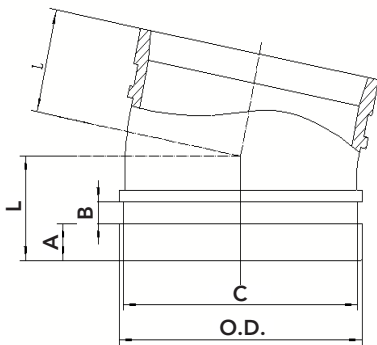

Grooved elbows provide an economical and efficient method of changing direction in grooved piping systems.

Reference		Nominal size		Pipe Ø O.D.	Grooved elbow 11,25° dimensions				Weight	Marking
Red	Galva	NPS inch	DN mm	mm	L mm	A mm	B mm	C mm	kg	
GB11R	GB11G	1¼	32	42,4	35	15,9	7,9	39,0	0,26	GB11 ¹⁾
GB11R	GB11G	1½	40	48,3	35	15,9	7,9	45,1	0,28	GB11 ¹⁾
GB11R	GB11G	2	50	60,3	35	15,9	7,9	57,2	0,42	GB11
GB11R	GB11G	2½	65	73,0	38	15,9	7,9	69,1	0,72	GB11
GB11R	GB11G	2½	65	76,1	38	15,9	7,9	72,3	0,71	GB11
GB11R	GB11G	3	80	88,9	38	15,9	7,9	84,9	0,72	GB11
GB11R	GB11G	4	100	108,0	45	15,9	9,5	103,7	1,13	GB11 ²⁾
GB11R	GB11G	4	100	114,3	45	15,9	9,5	110,1	1,24	GB11
GB11R	GB11G	5	125	133,0	51	15,9	9,5	129,1	1,82	GB11 ²⁾
GB11R	GB11G	5	125	139,7	51	15,9	9,5	135,5	1,72	GB11
GB11R	GB11G	5	125	141,3	51	15,9	9,5	137,0	1,82	GB11
GB11R	GB11G	6	150	159,0	51	15,9	9,5	154,5	4,62	GB11 ²⁾
GB11R	GB11G	6	150	165,1	51	15,9	9,5	160,9	2,45	GB11
GB11R	GB11G	6	150	168,3	51	15,9	9,5	164,0	2,68	GB11
GB11R	GB11G	8	200	219,1	51	19,1	11,1	214,4	3,88	GB11
GB11R	GB11G	10	250	273,0	54	19,1	12,7	268,3	5,20	GB11 ¹⁾
GB11R	GB11G	12	300	323,9	57	19,1	12,7	318,3	7,82	GB11 ¹⁾

Material specifications

- Housing:** ductile iron conform to ASTM A536 GR 65-45-12
- Coating:** red paint coating RAL 3000, EPD Epoxy coating

Working pressure

300 PSI/2068 kPa

General notes:

- ¹⁾ No FM-approval / ²⁾ No FM- and UL-approval.
- Pressure ratings listed are CWP (cold working pressure) or MWP (maximum working pressure) at a maximum service temperature of 50°C. This rating may occasionally differ from maximum working pressure listed and/or approved by UL and/or FM, as testing conditions and test pipes differ. For more information, please contact info@pipinglogistics.eu.
- Maximum working pressure listed is total of internal and external pressures, based on standard weight (ANSI) steel pipe and standard roll or cut groove, in accordance with Profit specifications. For more information, please contact info@pipinglogistics.eu.
- For one time field test only, the maximum joint working pressure may be increased one and a half times the figure shown.
- Warning: Piping systems must always be depressurized and drained before attempting disassembly and/or removal of any components.
- Profit reserves the right to change specifications, designs and/or standard equipment without notice and without incurring in any obligations.
- Profit red coated products are intended for piping with indoor application (EN 12944-2 corrosivity category C1 & C2). For outdoor installations near the sea (corrosivity category C3) we advise to use our hot dip galvanized couplings and fittings. For application in corrosivity category C4 (higher salinity climate) or higher, please contact info@pipinglogistics.eu.
- We strongly advise to always store our products in closed and dry warehouses.